

## PKS 70 10 CUGALNISN (472 436)

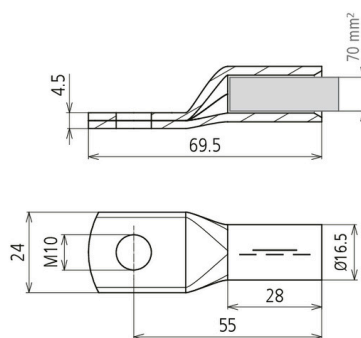

Figure without obligation



Crimped cable lug according to DIN 46235 with nickel barrier layer to avoid whisker formation.

Type	PKS 70 10 CUGALNISN
Part No.	472 436
Material	Cu/gal (Ni)Sn
Lightning impulse current (10/350 µs) Cugal (Ni)Sn 70 mm <sup>2</sup> (Rm/Rf) / stainless steel 40x10 mm	1HExIIC 100 kA (non-sparking) T4
Max. short-circuit current (AC 50 Hz / DC / 5 s) Cugal (Ni)Sn 70 mm <sup>2</sup> (Rm/Rf) / StSt 40x10 mm	2600 A / T4
Max. surface temperature T4	135 °C
Cable lug hole	M10
Conductor cross-section	70 mm <sup>2</sup>
Weight	65 g
Customs tariff number (Comb. Nomenclature EU)	85359000
GTIN	4013364470576
PU	3 pc(s)

Note: Non-sparking only ensured in connection with PAS EX ...!

We reserve the right to introduce changes in performance, configuration and technology, dimensions, weights and materials in the course of technical progress. The figures are shown without obligation.