

## D BEB 1-NR / EBS 15-03-19 (419 012)

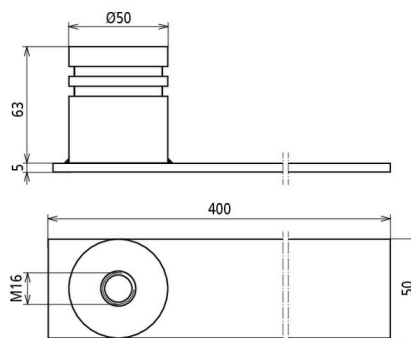

Figure without obligation



### Flat steel earthing bridges

The earthing bridges are designed for earthing, current return circuits and equipotential bonding in railway line applications. This version is installed flush with the surface and the angled flat steel is welded to the earthing reinforcement via a defined welding seam, particularly in installation situations where space is critical. This earthing bridge also has a technical approval from DB Netz AG and can therefore be reliably used in planning.

Type	D BEB 1-NR / EBS 15-03-19
Part No.	419 012
Material of connection element	StSt
Material No.	1.4301
Material of flat steel	S235
Short-circuit current	> 25 kA
Test current	40 kA / 100 ms
Standard	Ril 997.0205A01
Short-circuit current (AC 50 Hz / DC) (1 s; ≤ 300°C)	12.6 kA
Thread	M16
Diameter of connection plate	50 mm
Dimensions of flat steel	400 x 50 x 5 mm
Total height	63 mm
DB drawing No.	3 Ebs 15.03.19 - 36
Weight	1,46 kg
Customs tariff number (Comb. Nomenclature EU)	85369010
GTIN	4013364439467
PU	1 pc(s)

We reserve the right to introduce changes in performance, configuration and technology, dimensions, weights and materials in the course of technical progress. The figures are shown without obligation.