

D BEB 10-FLEX / EBS 15-03-19 (419 101)

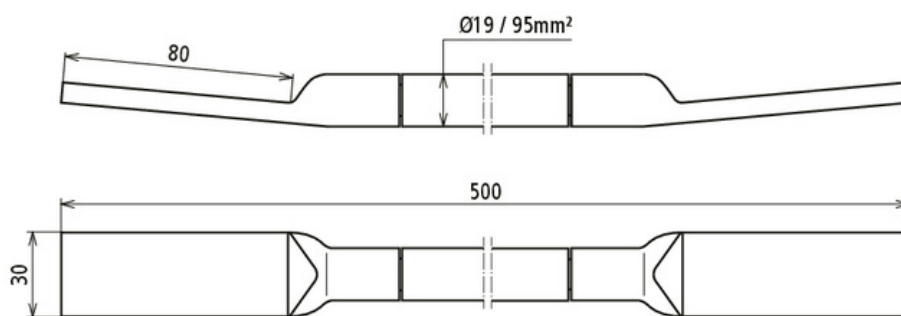

Figure without obligation



Copper cable earthing bridges

The earthing bridges are designed for earthing, current return circuits and equipotential bonding in railway line applications. This version establishes a non-visible connection within the concrete by welding the copper-plated steel lugs pressed onto the copper cable to the earthing reinforcement. The flexibility of the cable makes installation in the reinforcement easier for the user. The earthing bridges also have technical approval from DB Netz AG and can be reliably used in planning.

Type	D BEB 10-FLEX / EBS 15-03-19
Part No.	419 101
Material of lug	St / Cu
Material of cable	Cu
Short-circuit current	> 25 kA
Test current	40 kA / 100 ms
Standard	Ril 997.0205A01
Short-circuit current (AC 50 Hz / DC) (1 s; ≤ 300°C)	12.6 kA
Cable	H07V-K
Cable cross-section	95 mm ²
Cable diameter	19 mm
Dimensions of lug	80 x 30 mm
Length	500 mm
DB drawing No.	3 Ebs 15.03.19 - 33
Weight	337 g
Customs tariff number (Comb. Nomenclature EU)	85369010
GTIN	4013364439603
PU	1 pc(s)

We reserve the right to introduce changes in performance, configuration and technology, dimensions, weights and materials in the course of technical progress. The figures are shown without obligation.