

AKK DUL 8.10 KBF 3 20 STTZN (372 300)

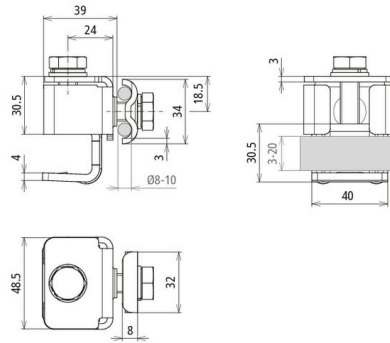

Figure without obligation

To penetrate the surface protection with the screw, the washer underneath the spring washer must be removed.



Arrangement:

Type	AKK DUL 8.10 KBF 3 20 STTZN
Part No.	372 300
Clamping range	3-20 mm
Material of clamp	St/tZn
Clamping range Rd	8-10 mm
Screw	⚙️ M10 x 32 mm / M10 x 18 mm
Screw / spring washer material	StSt
Type of connection	Releasable connection
Penetration of surface protection	Up to 0.2 mm with blade or blade and screw
Connection with	Double clamp
Lightning current carrying capability (10/350 µs)	⚡ 50 kA ⚡ 100 kA *)
Standard	EN 62561-1
Weight	251 g
Customs tariff number (Comb. Nomenclature EU)	85359000
GTIN	4013364515765
PU	25 pc(s)

*) For exact assignment, see test certificate.

We reserve the right to introduce changes in performance, configuration and technology, dimensions, weights and materials in the course of technical progress. The figures are shown without obligation.